

ПРОУШИНЫ ДЛЯ ПРОМЫШЛЕННЫХ ЦИЛИНДРОВ

ПРОУШИНА С ПРЕСС-МАСЛЕНКОЙ

CSTAPR...U

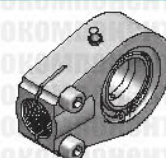
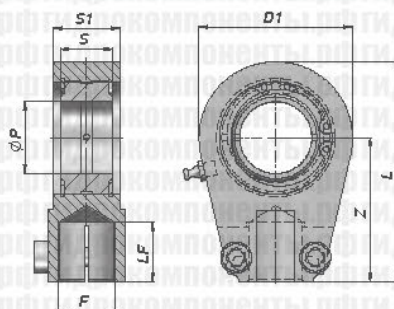

Обозн.	ØP	Z	S	D1 макс.	S1 макс.	L	F	LF мин.	FC (кН)	кг
CSTAPR020U	20	50	16	58.0	19.0	80	M16x1.5	17	30	0,44
CSTAPR025U	25	50	20	58.0	23.5	80	M16x1.5	17	48	0,47
CSTAPR030U	30	60	22	66.0	28.5	94	M22x1.5	23	62	0,77
CSTAPR035U	35	70	25	80.0	30.5	112	M28x1.5	29	80	1,24
CSTAPR040U	40	85	28	96.0	35.5	135	M35x1.5	36	100	2,12
CSTAPR050U	50	105	35	118.0	40.5	168	M45x1.5	46	156	3,74
CSTAPR060U	60	130	44	132.0	50.5	200	M58x1.5	59	245	6,49
CSTAPR070U	70	150	49	157.0	55.5	232	M65x1.5	66	315	9,88
CSTAPR080U	80	170	55	179.0	60.5	265	M80x2	81	400	14,20
CSTAPR090U (**)	90	210	60	208.0	65.5	322	M100x2	101	490	20,00
CSTAPR100U (**)	100	235	70	233.5	70.5	360	M110x2	111	610	27,50
CSTAPR110U (**)	110	265	70	268.0	80.5	407,5	M120x3	125	655	45,60
CSTAPR120U (**)	120	310	85	345.0	90.5	490	M130x3	135	950	72,00

FC = МАКС. ДИНАМИЧЕСКАЯ НАГРУЗКА

МАТЕРИАЛ: СТАЛЬ ISO 12240-1 СЕРИЯ W - (**)= ВЫСОКОПРОЧНЫЙ ЧУГУН

ПРОУШИНА С ПРЕСС-МАСЛЕНКОЙ

CSTAPR...N

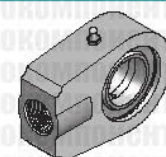
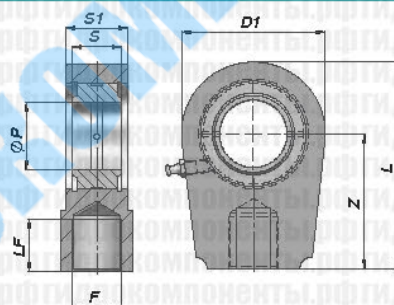

Обозн.	ØP	Z	S	D1 макс.	S1 макс.	L	F	LF мин.	FC (кН)	кг
CSTAPR020N	20	50	16	58.0	19.0	80	M16x1.5	17	30	0,45
CSTAPR025N	25	50	20	58.0	23.5	80	M16x1.5	17	48	0,49
CSTAPR030N	30	60	22	66.0	28.5	94	M22x1.5	23	62	0,76
CSTAPR035N	35	70	25	80.0	30.5	112	M28x1.5	29	80	1,26
CSTAPR040N	40	85	28	96.0	35.5	135	M35x1.5	36	100	2,15
CSTAPR050N	50	105	35	118.0	40.5	168	M45x1.5	46	156	3,80
CSTAPR060N	60	130	44	132.0	50.5	200	M58x1.5	59	245	6,20
CSTAPR070N	70	150	49	157.0	55.5	232	M65x1.5	66	315	9,83
CSTAPR080N	80	170	55	179.0	60.5	265	M80x2	81	400	13,97
CSTAPR090N (**)	90	210	60	208.0	65.5	322	M100x2	101	490	23,50
CSTAPR100N (**)	100	235	70	233.5	70.5	360	M110x2	111	610	32,00
CSTAPR110N (**)	110	265	70	268.0	80.5	407	M120x3	125	655	41,00
CSTAPR120N (**)	120	310	85	345.0	90.5	490	M130x3	135	950	72,00

FC = МАКС. ДИНАМИЧЕСКАЯ НАГРУЗКА

МАТЕРИАЛ: СТАЛЬ ISO 12240-1 СЕРИЯ E - (**)= ВЫСОКОПРОЧНЫЙ ЧУГУН